

AN-1082 Adjust or Synchronize LM2586/88 Switching Frequency

ABSTRACT

Switching frequency is a very important parameter in switching power converters. As the switching frequency increases, the physical size of magnetic elements and other components in the circuit reduce significantly. Switching frequency also plays a great role in control loop gain and compensation design. Switching frequency determines the maximum allowable bandwidth of the control loop. Switching frequency is also important parameter for EMI and noise issues. The EMI spectrum is a direct function of the switching frequency.

Contents

1	Introduction	2
2	Example	3
List of Figures		
1	Synchronizing LM2588 Boost to LM2596 Buck Regulator	2
2	Waveforms (Top-Synchronization Signal, Bottom-LM2588 Switch Waveform).....	3
List of Tables		
1	Frequency Settling Resistor Guide	2

1 Introduction

From the above cited reasons, it can be deduced that a great advantage will be gained by having control over the switching frequency. The SIMPLE SWITCHER® boost converters are available in two flavors. While the LM2585 and LM2587 operate at a fixed switching frequency of 100 kHz, the LM2586 and LM2588 allows its switching frequency to be modified. Using either of two control methods, the switching frequency can be varied between 100 kHz (its base frequency) to 200 kHz. Figure 1 shows the LM2586 boost regulator with synchronization and frequency adjust pins.

Synchronization forces the LM2586/8 switching frequency to match that of an external source, such as another switching regulator or a system clock. This keeps the EMI generated within the system to a predictable set of frequencies. It also prevents similar (but not matching) switching frequencies from producing a beat frequency. Both of these results make it easier to filter out switching noise in the system. By synchronizing to a higher frequency (>100 kHz) system clock or switching regulator, the LM2586/88 can be made to operate at higher frequencies, in order to reduce the size of the magnetic elements and other components.

The threshold voltage for the synchronization pin is typically around 0.75 V. The voltage levels of the clock signal should be 0 V and 2 V. If the synchronization pin is not used, it should be left open.

The second frequency control method changes the switching frequency of an LM2586/8, using a single resistor (from the Frequency Adjust pin to ground). Once again, this allows a design to be customized for a smaller size, as the sizes of the transformer and output capacitor tend to go down as the switching frequency increases. Table 1 shows the resistor values corresponding to commonly used frequencies.

If the Frequency Adjust pin is not to be used, it should be left open. Pulling this pin above 3 V will turn the regulator off.

Table 1. Frequency Settling Resistor Guide

R _{SET} (kΩ)	Frequency (kHz)
Open	100
200	125
47	150
33	175
22	200

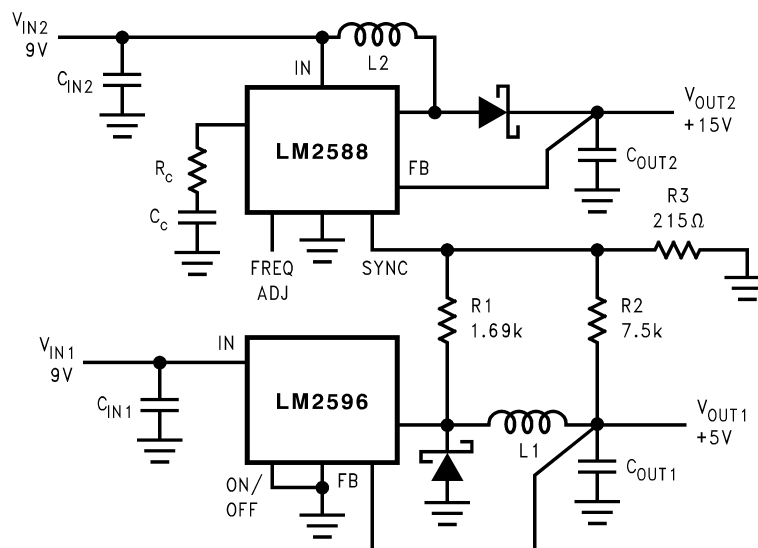

Figure 1. Synchronizing LM2588 Boost to LM2596 Buck Regulator

2 Example

In the example shown, the LM2588 has been synchronized to the 150 kHz LM2596. With the LM2596 output voltage of 5 V, the resistor divider of R1, R2, and R3 sets the voltage applied to the LM2588 SYNC pin to swing between 0.1 V and 1.5 V. To assure correct operation, the regulator designated “master” (in this case, the LM2596) must be in continuous operation (the current in inductor L1 must be continually above 0A). In addition, to keep the sync voltage at the designated levels, the input voltage to the master regulator (V_{IN1}) should not vary more than $\pm 10\%$. Synchronization of the LM2588 (or LM2586) occurs on the falling edge of the sync signal. The LM2596 buck converter and LM2588 boost regulator are designed using the *Switchers Made Simple* Software, SMS4.2.1. Figure 2 shows the diode and switch voltage waveforms of the buck and boost regulators, respectively.

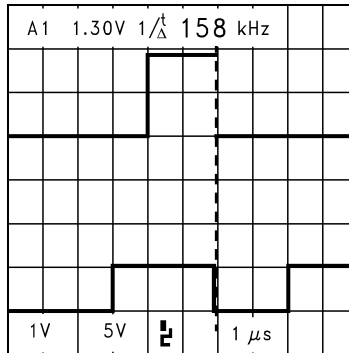

Figure 2. Waveforms (Top-Synchronization Signal, Bottom-LM2588 Switch Waveform)



南皇电子

IMPORTANT NOTICE

Texas Instruments Incorporated and its subsidiaries (TI) reserve the right to make corrections, enhancements, improvements and other changes to its semiconductor products and services per JESD46, latest issue, and to discontinue any product or service per JESD48, latest issue. Buyers should obtain the latest relevant information before placing orders and should verify that such information is current and complete. All semiconductor products (also referred to herein as "components") are sold subject to TI's terms and conditions of sale supplied at the time of order acknowledgment.

TI warrants performance of its components to the specifications applicable at the time of sale, in accordance with the warranty in TI's terms and conditions of sale of semiconductor products. Testing and other quality control techniques are used to the extent TI deems necessary to support this warranty. Except where mandated by applicable law, testing of all parameters of each component is not necessarily performed.

TI assumes no liability for applications assistance or the design of Buyers' products. Buyers are responsible for their products and applications using TI components. To minimize the risks associated with Buyers' products and applications, Buyers should provide adequate design and operating safeguards.

TI does not warrant or represent that any license, either express or implied, is granted under any patent right, copyright, mask work right, or other intellectual property right relating to any combination, machine, or process in which TI components or services are used. Information published by TI regarding third-party products or services does not constitute a license to use such products or services or a warranty or endorsement thereof. Use of such information may require a license from a third party under the patents or other intellectual property of the third party, or a license from TI under the patents or other intellectual property of TI.

Reproduction of significant portions of TI information in TI data books or data sheets is permissible only if reproduction is without alteration and is accompanied by all associated warranties, conditions, limitations, and notices. TI is not responsible or liable for such altered documentation. Information of third parties may be subject to additional restrictions.

Resale of TI components or services with statements different from or beyond the parameters stated by TI for that component or service voids all express and any implied warranties for the associated TI component or service and is an unfair and deceptive business practice. TI is not responsible or liable for any such statements.

Buyer acknowledges and agrees that it is solely responsible for compliance with all legal, regulatory and safety-related requirements concerning its products, and any use of TI components in its applications, notwithstanding any applications-related information or support that may be provided by TI. Buyer represents and agrees that it has all the necessary expertise to create and implement safeguards which anticipate dangerous consequences of failures, monitor failures and their consequences, lessen the likelihood of failures that might cause harm and take appropriate remedial actions. Buyer will fully indemnify TI and its representatives against any damages arising out of the use of any TI components in safety-critical applications.

In some cases, TI components may be promoted specifically to facilitate safety-related applications. With such components, TI's goal is to help enable customers to design and create their own end-product solutions that meet applicable functional safety standards and requirements. Nonetheless, such components are subject to these terms.

No TI components are authorized for use in FDA Class III (or similar life-critical medical equipment) unless authorized officers of the parties have executed a special agreement specifically governing such use.

Only those TI components which TI has specifically designated as military grade or "enhanced plastic" are designed and intended for use in military/aerospace applications or environments. Buyer acknowledges and agrees that any military or aerospace use of TI components which have **not** been so designated is solely at the Buyer's risk, and that Buyer is solely responsible for compliance with all legal and regulatory requirements in connection with such use.

TI has specifically designated certain components as meeting ISO/TS16949 requirements, mainly for automotive use. In any case of use of non-designated products, TI will not be responsible for any failure to meet ISO/TS16949.

Products

Audio	www.ti.com/audio
Amplifiers	amplifier.ti.com
Data Converters	dataconverter.ti.com
DLP® Products	www.dlp.com
DSP	dsp.ti.com
Clocks and Timers	www.ti.com/clocks
Interface	interface.ti.com
Logic	logic.ti.com
Power Mgmt	power.ti.com
Microcontrollers	microcontroller.ti.com
RFID	www.ti-rfid.com
OMAP Applications Processors	www.ti.com/omap
Wireless Connectivity	www.ti.com/wirelessconnectivity

Applications

Automotive and Transportation	www.ti.com/automotive
Communications and Telecom	www.ti.com/communications
Computers and Peripherals	www.ti.com/computers
Consumer Electronics	www.ti.com/consumer-apps
Energy and Lighting	www.ti.com/energy
Industrial	www.ti.com/industrial
Medical	www.ti.com/medical
Security	www.ti.com/security
Space, Avionics and Defense	www.ti.com/space-avionics-defense
Video and Imaging	www.ti.com/video

TI E2E Community

e2e.ti.com